



International Journal of Multidisciplinary Research and Growth Evaluation.

Knowledge management system: The impact on employee performance

Aprilliantoni

Unisma Bekasi Graduate School, Indonesia

* Corresponding Author: **Aprilliantoni**

Article Info

ISSN (online): 2582-7138

Volume: 04

Issue: 03

May-June 2023

Received: 20-04-2023

Accepted: 07-05-2023

Page No: 539-544

Abstract

This study intends to analyze the impact of Technology, Work Procedures, and Personal Knowledge on Employee Performance. This research is based on the notion of knowledge management system (KMS) which is increasingly important for an organization. The object of the research is the employee of PT Bank Central Asia.. Data collection method used was a questionnaire distributed to respondents research which is based on indicators that represent each variable. The analysis method used in this study show that, (1) Technology negative and significant effect on the performance employee, (2) Job procedure positive and significant impact on performance employee, (3) Personal knowledge positive and significant effect on the performance employee, and (4) Technology, Job procedure, Personal knowledge, together positive and significant impact on employee performance. Based on the research that has been done, the suggestions in this study is that in further research using more than 1 (one) object of study as a comparison Knowledge Management System, particularly related to the performance of the system at a banking industry.

Keywords: Knowledge management system, employee performance, structural equation modelling

Introduction

Skills are part of the modern human lifestyle. In addition, in a company, the role of knowledge possessed as a whole can increase the competitiveness and work efficiency of the organization concerned. In recent years, Knowledge Management has become an important study in promoting the creation, innovation, and knowledge sharing of an organization. This is evidence that an important resource for companies today is knowledge that is collectively owned by employees, customers, and vendors. Managing knowledge that comes from every element of the company systematically and linked to the company's business strategy is the main goal of knowledge management of an organization. Which is also known as Knowledge Management System.

An effective Knowledge Management System (KMS) will involve many elements, namely people, culture, processes, leadership, technology and system performance from the Knowledge Management System itself. With a good performance system that supports the knowledge system, the elements that are so broad will be able to support it properly and perfectly. A very important performance management system apart from supporting hardware and software is session limit. Session limit is an access limit that limits access for each employee to access the knowledge system. In the preparation of the architecture knowledge is positioned as a product, which is created, produced, distributed, acquired and utilized by the company's employees in a continuous cycle. By having a sufficient performance limit session, every employee in the company can utilize or access the knowledge system effectively. Performance systems that exist in the knowledge system can support the elements seen in the various processes experienced by the knowledge, and the performance system can be the main pillar of the Knowledge Management System (KMS) building.

Through the Knowledge Management System (KMS), the knowledge possessed by a company will be identified to improve performance and produce various innovations. Innovation in a company can be obtained through knowledge creation, which is one of the dimensions of the knowledge management process. Thus, the company continuously improves itself (continuous improvement) and produces continuous innovation to deal with an ever-changing environment.

Ways to increase knowledge include getting used to the culture of communication between employees, providing opportunities for learning, and promoting knowledge sharing both through learning forums. Where this effort will create and maintain increased value from the company's core competencies by utilizing existing information technology.

The company seeks to improve the quality and quantity of information provided in the form of knowledge to employees. In providing knowledge, companies cannot be separated from information technology which has a strong influence in supporting the provision of knowledge, where the company requires a knowledge management system with an adequate performance system or can support the knowledge system.

In managing knowledge, companies need a system that is currently known as a knowledge management system. Knowledge management is a system created to create, document, classify, and disseminate knowledge within a company. Therefore, knowledge is easy to use whenever needed, by anyone according to their level of competence and authority. The Knowledge Management System manages all system elements in the form of documents, databases, complete policies and procedures, along with information about the experience, expertise, and skills of individual and collective human resources owned by the company with the help of information technology. The management of Knowledge Management system elements is intended so that companies are always creative and efficient so that they have high competitiveness for a long period of time.

Knowledge Management System or abbreviated (KMS) to provide information in the form of knowledge. Knowledge Management System is an integrated approach of various disciplines which has stages, namely creating and growing and modifying knowledge then specifically formulating, compiling knowledge, sharing or distributing knowledge, utilizing knowledge and the last stage is knowledge development to achieve company goals.

Literature Review

KMS is a system designed to measure unit performance based on financial and operational benchmarks on a monthly basis. One of the inputs used in KMS is the application of KPI (Key Performance Indicators). With the implementation of this module, each unit in its operational activities will always be oriented towards service improvement so that it can meet its SLA/KPI, because this will affect the performance of the unit. Performance appraisal is carried out using a predetermined form and is implemented through a centralized computerized system to the Change Management Office (CMO) Unit.

The following are matters relating to PMS PT Bank Central Asia. Indonesia

a. Performance Appraiser

Assessment of employees is carried out in stages by superiors at two levels above (the employee concerned). For example, the Marketing Manager will be assessed by the Assistant Vice President of Marketing, then the results of the assessment will be considered and signed by the Vice President of Marketing. The Marketing Manager will sign and determine the results of the supervisor's assessment of an employee in the marketing department. And so on. So with this tiered method, it can minimize the element of subjectivity in performance appraisal.

b. Performance Appraisal Period

Assessment can be done monthly, quarterly, semi-annually (6

months) or annually. However, what is published to the company or head office is an employee performance appraisal which takes place on a semi-annual basis or every 6 months.

c. Mechanism of Scoring Assessment

Employee Performance Data will periodically be sent to the CMO Unit. Then based on these data, the CMO performs calculations using the PMS system with a rating scale of 1 to 5. A score of 5 is the score that indicates the best performance. An Assessment Form containing KPIs will be compiled and proposed by the respective Division leaders. Furthermore, through the supporting units in their respective divisions, the form is sent to the CMO to determine the standard score. After that, the Performance Assessment Form will be returned to the sending division, so that it can be used to measure the performance of its employees. Based on the performance score, the total value of the performance of each employee can be determined. The following is a total value scale of performance appraisal based on system performance.

Table 1: Performance Assessment Scale Based on KMS

Score Amount	Category
40 – 50	Very satisfactory
30 – 39	satisfactory
20 – 29	Good
10 – 19	Pretty good
< 10	Not enough

By considering the total value of the employee's performance being assessed, the company will determine the value of compensation for salary increases or bonuses periodically for the employee concerned or compensation can also be in the form of a promotion/position which is often known as a promotion. The previous year's assessment will be a reference in providing compensation for the current year.

Basically, tacit knowledge is personal, developed through experiences that are difficult to formulate and communicate (Carrillo *et al.*, 2004) ^[2]. Based on its understanding, tacit knowledge is categorized as personal knowledge or in other words knowledge obtained from individuals (individuals). Research on the nature of knowledge instantly reconciles the difference between knower and known, or often interpreted in terms of subject and object, or subjective and objective ingredients in experience.

Based on its understanding, tacit knowledge is categorized as personal knowledge or in other words knowledge obtained from individuals (individuals). According to personal knowledge is obtained from formal and informal instructions. Personal knowledge also includes memories, story-telling, personal relationships, books that have been read or written, notes, documents, photos, intuition, experiences, and everything else learned, from gardening to nuclear development.

The experience gained by each employee is certainly different based on unpredictable situations and conditions. The definition of experience taken from the English dictionary is the process of gaining knowledge or skills over a period of time through seeing and doing things rather than through studying. Which means the process of acquiring knowledge or abilities over a certain period by seeing and doing things rather than by learning. The more employees have high personal knowledge, it will produce better performance. Found empirical evidence that personal

knowledge has a direct effect on employee performance.

Job procedures are responsibilities or tasks that are formal in nature or official orders or ways of doing things. According to as one of the parties who sparked knowledge management, one concrete form of explicit knowledge is the Standard Operation Procedure done and guests will be familiar with the existing service system.

Furthermore, according to Standard is the first step to get the degree of suitability of a product, compared to guest expectations. Therefore, in order for a type of work to produce standard products from time to time, the ways of working to produce these products must also be carried out in standard ways. What is meant by standard products are:

1. Has a degree of suitability for the user.
2. Each type of product produced for use, consistently has the same specifications.

The more appropriate job procedures are carried out, the employee's performance will increase. Found empirical evidence that job procedures directly affect employee performance.

Technology is one of the main elements contained in knowledge management, known as a medium that facilitates the dissemination of explicit knowledge (Indriyati). Based on statement, initially knowledge management was driven by technology, especially explicit knowledge which was easier to organize. According to Shofa (2013) [2] technology is not new in knowledge management, and the experiences that have been formed by previous experts are taken into consideration for the formation of the technology itself.

One of the technologies applied to PT Bank Central Asia. Is a performance system developed to evaluate the performance of company employees? With several general indicators of performance, PT Bank Central Asia's performance system will make reports on the achievement of employee performance periodically within a certain time. Found empirical evidence that technology has a direct effect on employee performance.

(system performance) simultaneously have a positive and significant impact on employee performance.

Methodology

The research design uses hypothesis testing, namely research that aims to test hypotheses which generally explain the characteristics of differences or groups or the independence of two or more factors in a situation by analyzing exogenous (free) and endogenous (bound) variables. This study aims to examine the effect of Personal Knowledge (X1), Job Procedure (X2), and Technology (System Performance) (X3) variables on employee performance (Y) with a Likert scale measuring 1-5.

Personal knowledge (X1) obtained by room division employees is in the form of experience either from daily events or from other sources (Carrillo *et al.*, 2004) [2]. Job procedures (X2) are responsibilities or tasks that must be carried out by room division employees based on the existing Standard Operation Procedures and are formal in nature (Carrillo *et al.*, 2004) [2]. Technology (X3) is a medium for disseminating information through intranet facilities that are used to support every work activity in the company. (Carrillo *et al.*, 2004) [2] Performance (Y) the quality and quantity of work achieved by an employee in carrying out his duties in accordance with the responsibilities assigned to him.

Data collection technique

Collecting data in this study obtained through agket or questionnaire. This observation uses a questionnaire, which list of questions is arranged in the form of multiple choice questions. The Likert scale used is a method that measures attitudes by agreeing or disagreeing with certain subjects, objects, or events.

Data Validity Test

Validity test shows the extent to which a measuring instrument measures the construct to be measured. Homogeneity testing was carried out to test the validity analysis. To measure the validity of the construct can be identified through the value of the loading factor. In cases where there is high construct validity, a high loading value on a factor (latent construct) indicates that they converge at one point. The requirement that the data can be called valid if the loading factor is significant. Because the significant loading factor may still be of low value, the standardized loading estimate should be equal to 0.50 or more and ideally should be 0.70 (Ghozali, 2013) [3].

Data Reliability Test

Reliability test is a reliability test that aims to find out how far a measuring instrument is reliable or trustworthy. Reliability relates to the estimation of the extent of a measuring instrument, when viewed from the stability or internal consistency of the answers/questions if the observations are made repeatedly. If a measuring instrument is used repeatedly and the measurement results obtained are relatively consistent, then the measuring instrument is considered reliable and reliable. Testing the reliability of the data can be done by analyzing the values of Variance Extracted (AVE) and Construct Reliability (CR). According to Ghozali (2013) [3], the data criteria are called reliable if the AVE value is equal to or above 0.50 and the CR value is equal to or above 0.70.

According to Ghozali (2013) [3], there are steps that must be

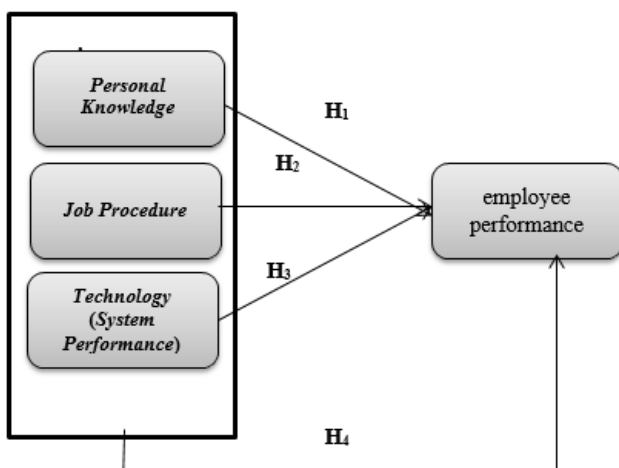

Fig 1: Research Thinking Framework

Hypothesis

- H₁:** Personal Knowledge has a positive and significant effect on employee performance
- H₂:** Job Procedure has a positive and significant effect on employee performance
- H₃:** Technology (System Performance) has a positive and significant effect on employee performance
- H₄:** Personal Knowledge, Job Procedure, and Technology

taken when using the Structural Equation Model (SEM), namely:

Develop theory based on model

In SEM, what must be done is to carry out a series of scientific explorations through literature review in order to obtain justification for the theoretical model developed. SEM is not used to produce a model, but is used to confirm the theoretical model through empirical data.

Research Instrument Test

After conducting a descriptive analysis of the research, at this stage the instrument test will be carried out. The instrument test is used to evaluate validity through standardized loading values and reliability through construct reliability (CR) and variance extracted (VE) (Ghozali, 2014) [3].

Confirmatory Factor Analysis (CFA) Test

The purpose of CFA is to confirm or test the model, that is, a measurement model whose formulation is derived from theory. According to CFA is used to test the unidimensional, validity and reliability of construct measurement models that

cannot be measured directly.

Table 2: Research Model Validity and Reliability Test Table

Variabel	Question Unit	Stanudardized Loading	Measurement Error	CR	AVE
Employee Performance	KK ₁	0,743	0,448	0,80	0,51
	KK ₂	0,520	0,730		
	KK ₄	0,729	0,469		
	KK ₅	0,824	0,322		
	PK ₁	0,605	0,629		
Personal Knowledge	PK ₂	0,268	0,856	0,893	0,630
	PK ₄	0,391	0,781		
	PK ₅	0,194	0,898		
	PK ₆	0,389	0,782		
	JP ₁	0,696	0,512		
Job Procedure	JP ₂	0,746	0,444	0,901	0,648
	JP ₃	0,731	0,214		
	JP ₄	0,887	0,466		
	JP ₅	0,805	0,352		
	T ₁	0,763	0,418		
Technology	T ₃	0,892	0,205	0,861	0,610
	T ₄	0,660	0,565		
	T ₅	0,794	0,370		

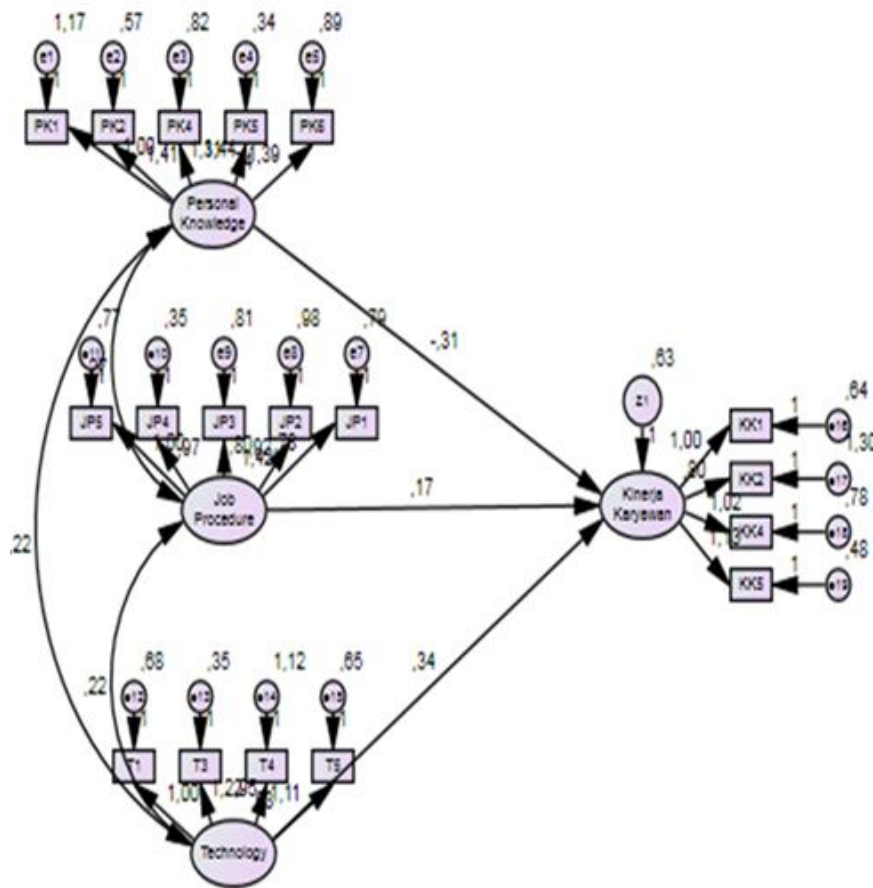

Fig 1: Structural Equation Model

Hypothesis testing

This study aims to analyze the effect of personal knowledge, job procedures, and technology on employee performance

using Structural Equation Modeling (SEM) analysis techniques. By referring to the structural equation model in Figure, the following is a test of the research hypothesis.

Table 3: Hypothesis Test Results

Hypothesis	Estimates	t Value	Significance	Conclusion
Employee Performance <--- Tecnology	-0,312	-2,764	0,006	Hypothesis rejected
Employee Performance <--- Job Procedure	0,173	2,262	0,024	Hypothesis accepted
Employee Performance <--- Personal Knowledge	0,343	3,432	0,000	Hypothesis accepted
Hypothesis	F Table	F count	Significance	Conclusion
Employee Performance <--- Personal Knowledge, Job Procedure, Technology	2,676	7,395	0,000	Hypothesis accepted

Based on the table above, the following is a description of the results of hypothesis testing:

1. The effect of technology (system performance) on employee performance is negative and significant. This is because the t Value of -2.764 is greater than 1.96. In addition, the significance of 0.006 is smaller than 0.05. The conclusion obtained based on the research results is that the hypothesis is rejected. This is because the direction of the relationship is negative.
2. The effect of job procedures on employee performance is positive and significant. This is because the t Value of 2.262 is greater than 1.96. In addition, the significance of 0.024 is smaller than 0.05. The conclusion obtained based on the results of the study is that the hypothesis is accepted.
3. The effect of personal knowledge on employee performance is positive and significant. This is because the t Value of 3.432 is greater than 1.96. In addition, the significance of 0.000 is smaller than 0.05. The conclusion obtained based on the research results is that the hypothesis is rejected because the hypothesis proposed is positive and significant.
4. The effect of personal knowledge, job procedures, and technology (System Performance) simultaneously is positive and significant. This is because the calculated F value of 7.395 is greater than F Table of 2.676. In addition, the significance value of 0.000 is greater than 0.05. The conclusion obtained based on the results of the study is that the hypothesis is accepted.

Results and Discussion

The Influence of Technology (System Performance) on Employee Performance

Based on the results of the study, it is known that technology has a negative and significant effect on employee performance. The results of this study contradict the hypothesis previously proposed that technology has a negative and significant effect on employee performance. The results of this research are because the use of technology through system performance at PT Bank Central Asia is still not able to optimize employee performance. There are many limitations to the implementation of system performance in the company. Lack of licenses (licenses system) to be able to access the KMS system at PT Bank Central Asia, weekly report knowledge that cannot be seen and displayed, and the lack of KMS Bandwidth system at PT Bank Central Asia which causes the KMS system to be slow to use and has a negative effect on performance employee.

The Influence of Job Procedures on Employee Performance

Based on the results of the study, it is known that job procedures have a positive and significant effect on employee performance. This is because job procedures are a form of explicit knowledge that describes the duties and functions of employees according to their respective positions and responsibilities. With proper implementation and supervision

of job procedures, employees will get guidelines regarding things that must be achieved to significantly improve performance. As the party who initiated knowledge management, stated that one concrete form of explicit knowledge is the Standard Operation Procedure. Will be familiar with the existing service system.

The Influence of Personal Knowledge on Employee Performance

Based on the results of the study, it is known that personal knowledge has a positive and significant effect on employee performance. This is in line with the theory described previously and previous research conducted Novealdi (2012)^[10] that personal knowledge has a positive and significant effect on employee performance. The results of this study are because employees have a good understanding of work experience as a form of knowledge to increase insight and capacity and can be shared with other employees as knowledge sharing can improve employee performance and the company as a whole.

Effect of Personal Knowledge, Job Procedure, and Technology (System Performance) Simultaneously on Employee Performance

Based on the research results, it is known that technology, job procedures, and personal knowledge together have a significant effect on employee performance. This is because in the current era of knowledge, knowledge management aims to improve and improve the company's operations in achieving competitive advantage and increasing profits. The concept of knowledge management in a company also aims to improve performance by fostering a culture of knowledge sharing, where knowledge is an asset that can be managed so that it can be communicated and used together (Priambada *et al*, 2010)^[11]. The results of this study are in line with previous research conducted which states that any form of knowledge management can significantly improve employee performance in an organization or company.

Conclusion

This study aims to analyze the effect of Technology, Job Procedure, and Personal Knowledge variables on the performance of PT Bank Central Asia's employees. After testing the effect through structural equations, here are some conclusions in this study:

- a. Technology (System Performance) has a negative and significant effect on employee performance
- b. Job procedures have a positive and significant effect on employee performance
- c. Personal Knowledge has a positive and significant effect on employee performance
- d. Personal Knowledge, Job Procedure and Technology (System Performance) simultaneously have a positive and significant effect on employee performance.

References

1. Bornemann Manfred, *et al.* An Illustrated Guide to Knowledge Management, Wissen management Forum. Graz, Austria; 2003.
2. Carrillo P, Robinson H, Al-Ghassani A, Anumba C. Knowledge management in UK construction: Strategies, resources and barriers. *Project Management Journal*; 2004:35(1).
3. Ghozali Imam. Model Persamaan Struktural Konsep & Analisis Dengan Program AMOS 21. Semarang: UNDIP Press; 2013.
4. Hendrik. Sekilas tentang Knowledge Management. Ilmu; 2003. Komputer.com.
5. Indriati Ratna. Kajian Knowledge Management dan Pengaruhnya Terhadap Kinerja Karyawan. Skripsi. Fakultas Ekonomi Universitas Diponegoro; 2008.
6. Jeremia Tuage, Bernhard Tewal, Dan Yantje Uhing. Kontribusi Gaya Kepemimpinan, Pelatihan dan Motivasi Kerja Terhadap Kinerja Pegawai Pada SEKDA Kabupaten Kepulauan Talaud. *Jurnal EMBA*; 2014:2(1).
7. Kusumawati Ratna. Analisis Pengaruh Budaya Organisasi Dan Gaya Kepemimpinan Terhadap Kepuasan Kerja Untuk Meningkatkan Kinerja Karyawan. Tesis. Program Pasca Sarjana Universitas Diponegoro Semarang; 2013.
8. Maimunah El Rayeb, S Augury, Dan Siti. Knowledge Management Sebagai Salah Satu Jembatan Pengembangan Institusi Unggulan. *Jurnal AMIK Raharja*; 2008:2(1).
9. Munir Ningky Sasanti. Penerapan Manajemen Pengetahuan Di Perusahaan Indonesia. *Jurnal PPM Management*; 2008.
10. Novealdi. Pengaruh Knowledge Management Terhadap Kinerja Karyawan: Studi Pada Rumah Sakit Bethesda Yogyakarta Skripsi. Fakultas Ekonomi Universitas Diponegoro; 2012.
11. Priambada D Boy, Azhari Gunawan, Dan Fahmi Idris. Implementasi Knowledge Management System di Perusahaan. *Tesis*. Program Pascasarjana Ilmu Komputer IPB, Bogor; 2010.
12. Shofa. Pengaruh Knowledge Management Terhadap Kinerja Karyawan: Studi Pada Karyawan Room Division Hotel Patra Jasa Semarang. Skripsi. Fakultas Ekonomi Universitas Diponegoro; 2013
13. Sinambela Lijan Poltak. Kinerja Pegawai Teori, Pengukuran dan Implikasi. Yogyakarta: Graha Ilmu; 2012.